

Cavity Slide Tie

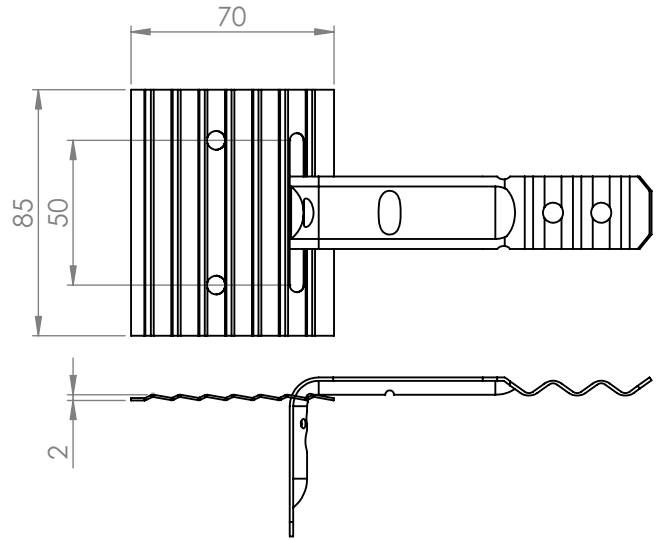

Medium duty shown - sliding bracket interchangeable

DESCRIPTION

Cavity slide tie. For fastening masonry to new or existing structures. install flush with clay bricks and 15mm clearance with other types of masonry.

FEATURES

- Clay brick
- Maximum cavity 125mm
- Medium & heavy duty
- Universal applications / remedial
- Australian design & tested AS/NZS 2699.2:2020

CORROSION CHARACTERISTICS

Galvanised Z600 (R2)
 Hot dipped galvanising (R3)
 Stainless steel 316L (R4)
 Conforms to corrosion resistance set by AS/NZS 2699.2:2020 / AS 3700.

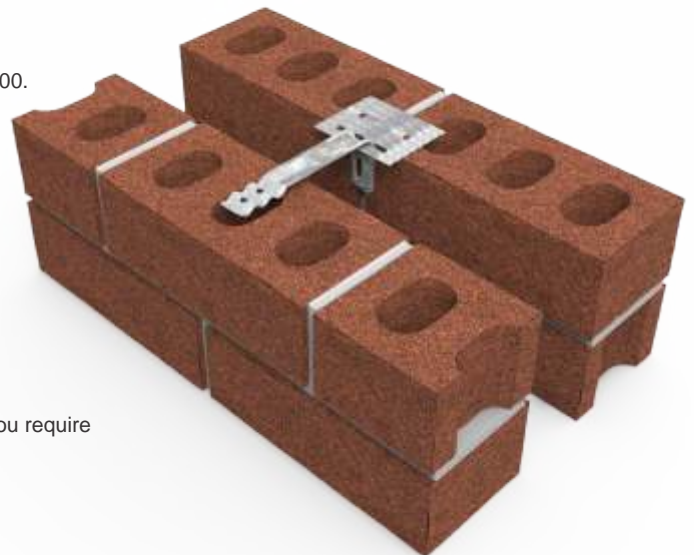

ORDERING INFORMATION

When ordering please supply use with the part number and quantity you require

